

Model SCV-1

Instruction Manual

Valid as of: 01.02.2017 • Please keep the manual for future reference!

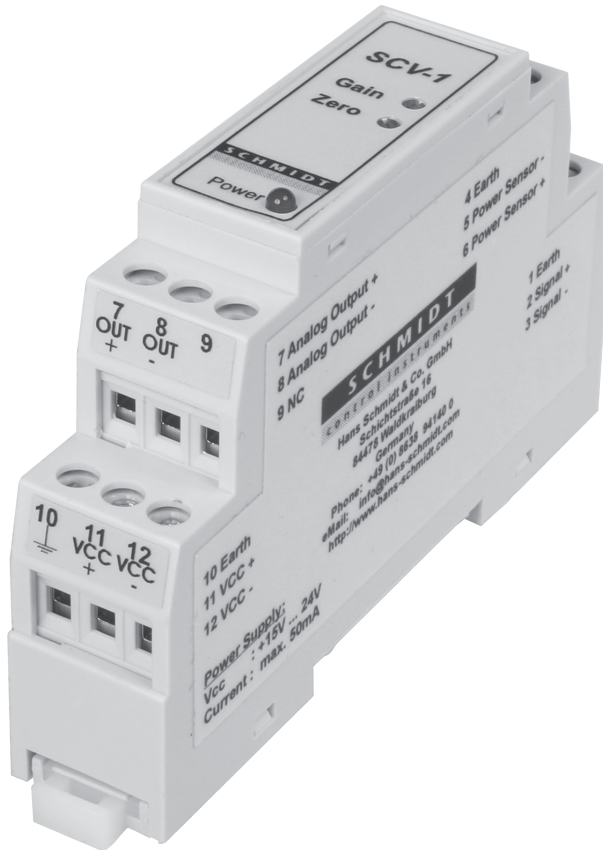

Contents

1	Warranty and Liability	3
1.1	Notices within the Operating Instructions	3
1.2	Responsibilities of the Operating Company	3
1.3	Responsibilities of the Personnel	3
1.4	Informal Safety Measures	4
1.5	Training of the Personnel	4
1.6	Intended Use	4
1.7	Dangers in Handling the Device	4
1.8	Copyright	4
1.9	Declaration of Conformity, RoHs II and WEEE Registration	4
2	Specifications	5
2.1	Pin Assignments of connectors and cable	5
2.2	Delivery Includes	6
2.3	Unpacking	6
3	Operating Procedure	6
3.1	Notes Before Starting Measurement	6
3.2	Initial Setup	7
3.3	Internal Adjustment of the Sensors	7
3.3.1	ZERO Adjustment	7
3.3.2	GAIN Adjustment	8
4	Service and Maintenance	9
4.1	Rollers	9
5	Cleaning	9
6	Verification Interval	9
6.1	Verification of Calibration and Determination of Repair Costs	10
7	Correspondence	11
8	Repairs	11

1 Warranty and Liability

In principle, the supply of the device is subject to our "General Conditions of Sale and Delivery." These have been provided to the operating company on conclusion of the contract, at the latest.

Warranty:

- SCHMIDT tension meters are warranted for 12 months.

Parts subject to wear, electronic components and measuring springs are not covered by the warranty. No warranty or liability will be accepted for bodily injury or property damage resulting from one or several of the following causes:

- Misuse or abuse of the device.
- Improper mounting, commissioning, operation and maintenance of the device (e.g. verification interval).
- Operation of the device if any safeguards are defective or if any safety and protection precautions are not properly installed or not operative.
- Failure to comply with the notices in the Operating Instructions regarding transport, storage, mounting, commissioning, operation, maintenance and setup of the device.
- Any unauthorized structural alteration of the device.
- Insufficient inspection of device components that are subject to wear.
- Opening the device or improper repair work.
- Disasters caused by the effects of foreign objects or by force majeure.

1.1 Notices within the Operating Instructions

The fundamental prerequisite for the safe handling of this device and its troublefree operation is the knowledge of the basic safety notices and safety instructions.

These Operating Instructions contain the most important notices for the safe operation of the device.

These Operating Instructions, in particular the safety notices, must be observed by any person who works with the device. In addition, the local valid rules and regulations for the prevention of accidents must be complied with.

The representations within the Operating Instructions are not true to scale.

The dimensions given are not binding.

General indications of direction, such as FRONT, REAR, RIGHT, LEFT apply when viewing the front of the device.

1.2 Responsibilities of the Operating Company

In compliance with the EC Directive 89/655/EEC, the operating company agrees to only permit persons to work with the device who:

- are familiar with the basic regulations on industrial safety and accident prevention and who have been trained in handling the device.
- have read and understood the chapter on safety and the warning notices in these Operating Instructions and have confirmed this with their signatures.
- are examined regularly on their safe and conscientious working method.

1.3 Responsibilities of the Personnel

All persons who work with the device agree to perform the following duties before starting work:

- to observe the basic regulations on industrial safety and accident prevention.
- to read the chapter on safety and the warning notices in these Operating Instructions and to confirm with their signatures that they have understood them.

1.4 Informal Safety Measures

The Operating Instructions must always be kept on hand where the device is operated. Apart from the Operating Instructions, the general and local valid regulations on accident prevention and environmental protection must be provided and complied with.

1.5 Training of the Personnel

Only trained and instructed personnel is permitted to work with the device. The responsibilities of the personnel must be clearly defined for mounting, commissioning, operation, setup, maintenance, and repair. Trainees may only work with the device under the supervision of experienced personnel.

1.6 Intended Use

The device is intended exclusively to be used as a tension meter. Any other use or any use exceeding this intention will be regarded as misuse. Under no circumstances shall HANS SCHMIDT & Co GmbH be held liable for damage resulting from misuse.

The intended use also includes:

- Complying with all notices included in the Operating Instructions and observing all inspection and maintenance works.

1.7 Dangers in Handling the Device

The device was designed according to the state of the art and the approved safety standards. Nevertheless, its use may cause serious or fatal injury to the user or third persons, and/or an impairment of the device or of other material assets.

The device may only be applied:

- For its intended use in a faultless condition with regard to the safety requirements.
- Malfunctions that could impair safety must be remedied immediately.
- Personal protective equipment must be used according to the EC Directive 89/686/EEC.



The device must not be operated in potential explosive areas and must not come into contact with aggressive substances.

1.8 Copyright

The copyright on these Operating Instructions remains with the company HANS SCHMIDT & Co GmbH.

These Operating Instructions are intended for the operating company and its personnel only. They contain instructions and notices that may only be reproduced on the prior written permission of

HANS SCHMIDT & Co GmbH

and under indication of the complete reference data.

Violations will be prosecuted.

1.9 Declaration of Conformity, RoHs II and WEEE Registration

In compliance with the EU Directives 2014/30/EU and 2011/65/EU



HANS SCHMIDT & CO GmbH is registered in compliance with the German Electrical and Electronic Equipment Act (ElektroG) under WEEE Reg. No. DE 48092317.

2 Specifications

Calibration:	According to SCHMIDT factory procedure
Genauigkeit:	± 2 % FS* oder besser Other calibration material: ± 3 % FS* or better
Overload Protection:	100 % of range
Measuring Principle:	Strain gauge bridge
Gehäuse:	Aluminium
Meas. Roller Deflection:	0.5 mm, max.
Signal Processing:	analog
Output Signal:	Standard: 0 - 10 V DC, impedance: > 5 kOhm Code A2: 0 - 10V Code A3: 4 - 20 mA
Damping (f_g):	Standard: approx. 30 Hz (others values on request)
Temperature Coefficient:	Zero point: less than ± 0.1 % FS* / °C
Temperature Range:	10- 45 °C
Air Humidity:	85% RH, max.
Power Supply:	15 ... 24 V DC, 21 mA (regulated)
Housing:	DIN EN top hat rail box; 17.5 mm plastic
	*Full Scale

2.1 Pin Assignments of connectors and cable

1 To assure immunity to random noise, the measuring head must be installed in such a way that it is insulated from ground (GND).
The shield of the connecting cable must be connected to the metal housing of the connecting plug



Pin Assignments from outside:

- 1 = earth/shield
 - 2 = + signal from sensor
 - 3 = - signal from sensor
 - 4 = earth/shield
 - 5 = - sensor power supply
 - 6 = + sensor power supply
 - 7 = + analog out
 - 8 = - analog out
 - 10 = earth/shield
 - 11 = + power supply
 - 12 = - power supply
- Pin 9 not assigned

fig. 2.1

	Series TS Code A10	Series MZ Code A10	Series SF
signal - in	white	green	green
signal + in	grey	yellow	white
excitation -	pink	brown	brown
excitation +	yellow	white	yellow

2.1 Pin Assignments of connectors and cable



The max. cable length between sensor and amplifier may not be more than 15 m.

The cable may not be laid in areas with EM fields.

2.2 Delivery Includes

Sensor

1 external amplifier

1 connecting cable

1 operating Instruction

2.3 Unpacking

Unpack the instrument and inspect it for any shipping damage. Notices of defect must be filed immediately, in writing, at the latest within 10 days on receipt of the goods.

3 Operating Procedure

3.1 Notes Before Starting Measurement



Tensions that exceed the tension range of the instrument by more than 100% may cause permanent damage to the measuring spring and must be avoided under any circumstances.

Sensors without display unit do not subject the EU machinery directive and must not be provided with a CE sign.

CE conformity testing was carried out and successfully passed by Hans Schmidt & Co GmbH with a complete unit consisting of:
TSB1 sensor, SCB-D1 display unit and an 8 m long connecting cable (special cable).

In no event shall HANS SCHMIDT & Co GmbH take over any warranty coverage for, or shall be held liable for, any damage resulting from self-made cables..

The model number, the serial number, the calibration label (option) and the SCHMIDT Quality Seal are provided on the cylindrical portion of the sensor.

3.2 Initial Setup

- Install sensor and amplifier at the desired measuring location.
- Connect the sensor to the amplifier, as well as the amplifier to the supplied or existing display unit. The pin assignment of the amplifier is described in Chapter 2.1
- Mount the pneumatic hose (inner diameter 3 mm) at the sealing gas connection of the sensor (flow rate 3 Ltr./min) - option
- If the material path is other than vertical or if the process material deviates significantly from the SCHMIDT calibration material, you need to carry out zero adjustment and gain adjustment as described in Chapters 3.3.1 and 3.3.2 before starting measurement.
- Allow approx. 10 minutes for thermal stabilization of the sensor.
- Thread the process material through the measuring and guide rollers, following the material path symbol on the front of the sensor.

3.3 Internal Adjustment of the Sensors

General information:

If the sensor has been delivered with a display unit, the ZERO and GAIN adjustments should only be carried out with the supplied display unit.

All tension meters are calibrated with standard materials - such as polyamide monofilament (PA) - according to the SCHMIDT factory procedure; the material path is vertical. Any difference in process material size and rigidity from the standard material may cause a deviation of the accuracy.

In 95 % of all industrial applications the SCHMIDT calibration has been proven to provide the best results and is used for comparative purposes.

If required you can also operate the sensors with a material path other than vertical (TSB2 horizontal).

Should the process material differ significantly from the SCHMIDT calibration material in size, rigidity or shape, we recommend special calibration using customer supplied material. If the material path is other than vertical or if the process material deviates significantly from the SCHMIDT calibration material, you need to carry out static **ZERO** and **GAIN adjustment** as described in Chapters 3.3.1 and 3.3.2.

3.3.1 ZERO Adjustment

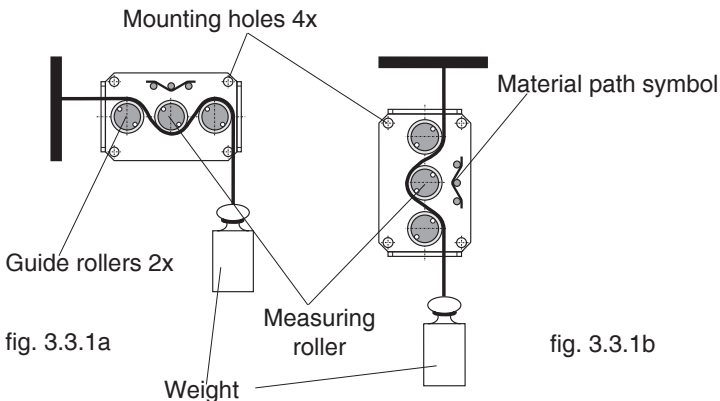

- Install the sensor in the desired position at the measuring location using the provided mounting holes.

3.3.1 ZERO Adjustment (Cont.)

- Screw the countersunk bolts (M2.5) labelled ZERO and GAIN all the way out on the rear side of the sensor.
- Allow approx. 10 minutes for thermal stabilization of the sensor.
- Thread the process material through the measuring and guide rollers, following the material path symbol on the front of the sensor.

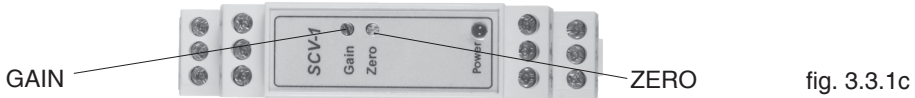

When threading the process material through the rollers, follow the material path symbol on the front of the sensor. If a force is applied to the middle sensor roller in the incorrect direction, damage could result.

Since ZERO and GAIN adjustments are always performed statically, the readings may differ under dynamic load.

- Hang a weight that corresponds to e.g. 10 % of the tension range from the process material.
- Connect a volt meter to pins 1 and 7 of the connector on the rear side of the unit.
- Adjust the potentiometer, which you can reach through the ZERO hole in the housing, with a screwdriver (with a point width of max. 1.9 mm) until the display of the connected volt meter reads,
for example:
Sensor model TS-200:
Weight 20 cN = Display 0.100 V for the TS standard version
or
Weight 20 cN = Display 1.00 V for the TS version with 10 V output signal.



Do not insert the screwdriver at an angle as this may damage the potentiometer.

3.3.2 GAIN Adjustment

Requirement: ZERO adjustment carried out.

Thread the process material through the measuring and guide rollers, following the material path symbol on the front of the sensor.

- Hang a weight that corresponds to e.g. 95 % of the tension range from the process material.
- Adjust the potentiometer, which you can reach through the GAIN hole in the housing, with a screwdriver (with a point width of max. 1.9 mm) until the display of the connected volt meter reads,
for example:
Sensor model TS-200:
Weight 190 cN = Display 0.950 V for TS standard version
or
Weight 190 cN = Display 9.50 V for TS version with 10 V output signal.



Do not insert the screwdriver at an angle as this may damage the potentiometer.

- Check the adjustments with a new filament of the process material and repeat the procedure, if required, as described in Chapters 3.2.1 and 3.2.2.

- 8 - Screw the ZERO and GAIN countersunk bolts back in on the rear side of the sensor.

4 Service and Maintenance

The tension meter is easy to maintain. Depending on operating time and load, the instrument should be checked according to the locally valid regulations and conditions (as described in Chapter 3.3). The use of other test methods than the procedure described in Chapter 3.3 may cause deviating measuring results.

4.1 Rollers

You should regularly inspect the rollers to assure that they are running easily and smoothly. You can replace the rollers yourself, as necessary. Please indicate the tension meter model and the serial number in your spare-parts order.

5 Cleaning

For cleaning the unit, do not use any



AGGRESSIVE SOLVENTS

such as trichloroethylene or similar chemicals.



NO WARRANTY OR LIABILITY

shall be accepted for damage resulting from improper cleaning.

6 Verification Interval

The question of finding the right frequency of calibration accuracy verification depends on several different factors:

- ➔ Operating time and load of the SCHMIDT tension meter
- ➔ Tolerance band defined by the customer
- ➔ Changes to the tolerance band compared to previous calibrations

Therefore, the interval between verifications of calibration must be determined by the user's Quality Assurance Department, based on the user's experience.

Assuming normal operating time and load as well as careful handling of the tension meter, we recommend a verification interval of one year.

6.1 Verification of Calibration and Determination of Repair Costs

Flow chart for verifying the calibration of used tension meters, incoming and outgoing verification with Inspection Certificate 3.1 according to DIN EN 10204

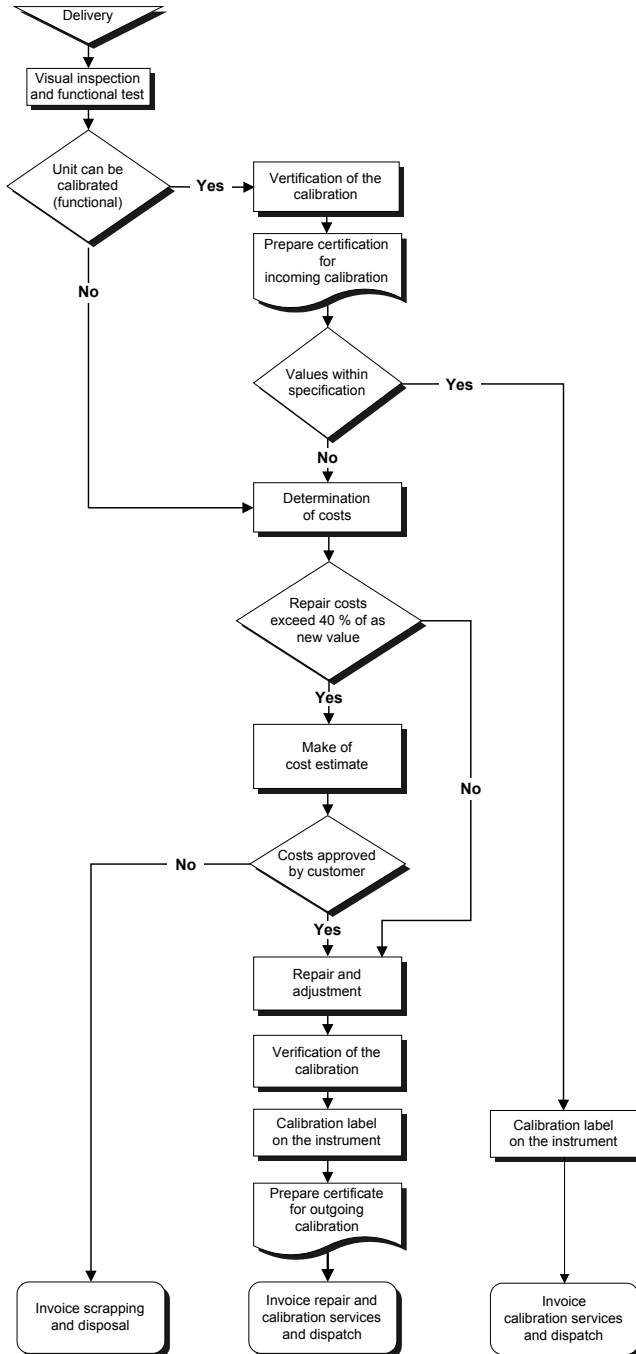

7 Correspondence

Should you have any questions regarding the instrument or Operating Instructions, or their use, please indicate above all the following details which are given on the ID plate:

- 1) Model
- 2) Serial number

8 Repairs

Shipping instructions:

We kindly ask for return free of charge for us, if possible by airmail parcel. All occurring charges, if any (such as freight, customs clearance, duty etc.), will be billed to customer. For return from foreign countries, we ask you to include a proforma invoice with a low value for customs clearance only, e.g. 50 Euro, each and to advise the shipment in advance by fax or eMail.

i To avoid unnecessary follow-up questions, and the resulting loss of time or possible misunderstandings, please return the instrument with a detailed fault description to our service department. Please indicate in your order whether you require an Inspection Certificate 3.1 according to DIN EN 10204.



Tension Meter



Force Gauge



Torque Meter



Tachometer



Speed- and Lengthmeter



Electronic Lengthmeter



Stroboscope



Screen Printing Tension Meter



Thickness Gauge



Yarn Package Durometer and Shore-A Durometer



Sample Cutter



Balance



Moisture Meter



Leak Tester



Softometer

CHECKLINE®
MADE TO MEASURE

600 Oakland Ave • Cedarhurst, NY 11516 USA
Checkline.com • info@Checkline.com • 516-295-4300