

# Force Test Stands Series **ES**

---

MODEL ESM301

## User's Guide

## ***Thank you...***

Thank you for purchasing a Mark-10 ESM301 Programmable Force Test Stand, designed for producing up to 300 lbF (1.5 kN) of tension or compression force. The ESM301 is an essential component of a force testing system, typically also comprising a force gauge and grips.

With proper usage, we are confident that you will get many years of great service with this product. Mark-10 test stands are ruggedly built for many years of service in laboratory and industrial environments.

This User's Guide provides setup, safety, and operation instructions. Dimensions and specifications are also provided. For additional information or answers to your questions, please do not hesitate to contact us. Our technical support and engineering teams are eager to assist you.

**Before use, each person who is to use the ESM301 should be fully trained in appropriate operation and safety procedures.**

## **TABLE OF CONTENTS**

<b>LIST OF INCLUDED ITEMS</b> .....	2
<b>OVERVIEW</b> .....	2
<b>MECHANICAL SETUP AND SAFETY</b> .....	3
<b>OPERATION BASICS</b> .....	7
<b>TEST PARAMETER SETUP</b> .....	9
<b>OPERATING MODES</b> .....	22
<b>COMMUNICATING WITH MESURGAUGE SOFTWARE</b> .....	30
<b>FEATURE ACTIVATION</b> .....	33
<b>MAINTENANCE AND SERVICE</b> .....	35
<b>SPECIFICATIONS</b> .....	37
<b>DIMENSIONS</b> .....	37

## 1 LIST OF INCLUDED ITEMS

Qty.	Item
1	ESM301 test stand
4	Force gauge mounting screw
1	User's guide (this booklet)
1	Power cord
1	Cable, controller to test frame, 6"
1	Cable, USB to RJ11 (for optional integrated travel indication)
1	ESM301-002-X column extension (optional)
1	ESM301-003 bench mounting kit (optional)
1	09-1143 multi-function cable (optional)
1	09-1056 serial cable (optional)
1	Accessories kit (small hook, medium hook, 2" diameter compression plate, 2" extension rod, #10-32 coupler, tool kit)

## 2 OVERVIEW

The ESM301 has three functional modes:

### 1. OPERATING MODE

This is the operating mode in which testing sequences can be started and stopped.

### 2. TEST PARAMETER SETUP

In this mode, test parameters are configured, such as rate of speed, number of cycles, password editing, and other parameters.

### 3. FEATURE ACTIVATION SETUP

This facility allows the user to enable features not originally purchased through a code activation process.

## 3 MECHANICAL SETUP & SAFETY

### 3.1 Appropriate Test Samples

Typical materials able to be tested by the ESM301 include many manufactured items, such as springs, electronic components, fasteners, caps, films, mechanical assemblies, and many others. Items that should not be used with the ESM301 include potentially flammable substances or products, items that can shatter in an unsafe manner, and any other components that can present an exceedingly hazardous situation when acted upon by a force.

### 3.2 Using Grips & Fixtures With The ESM301

Ensure that the grip or fixture is positioned to ensure axial load with respect to the loading shaft of the force gauge. When using a grip, ensure that it secures the sample in such a way that it is prevented from slipping out during a test, preventing a potential safety risk to the operator and others in the vicinity. If using a grip or fixture from a supplier other than Mark-10, ensure that it is constructed of suitably rugged materials and components.

### 3.3 Mounting

Place the stand on a clean, flat and level work area free from vibration. If desired, the stand can be secured to the work area with 1/4-20 screws fastened into the underside of the base. Failure to properly mount the test stand may make it more vulnerable to tipping, causing a hazardous situation.



**IMPORTANT: Do not fasten any screws more than 0.25 in [6 mm] into the base of the test stand, or damage to internal components can occur.**

The test stand can also be mounted using the ESM301-003 mounting kit. Screws of various lengths are supplied with this kit to accommodate a range of bench thicknesses. Refer to the following illustration for proper assembly:

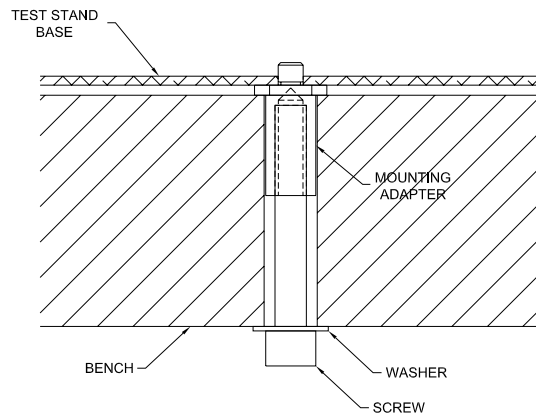

In general, the ESM301 can be mounted at any angle, although extra care should be taken during installation and operation.

Once the test stand is in a stable and secure position, install a force gauge with four thumb screws (provided). All Mark-10 gauges (except the Series CG) mount directly without adapters. Grips can be mounted onto the force gauge and test stand base.

### 3.4 Setting Up The Controller

The power plug and controller cable must be connected to the rear of the controller, as shown in the illustration below:

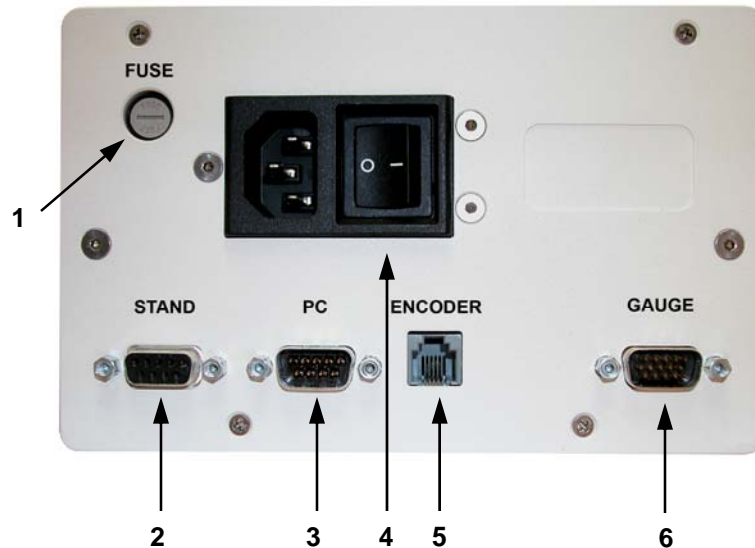

**1. Fuse**

**2. Controller Cable Connector**

Plug one end of the cable into this connector, and the other end into the connector as shown in the illustration on the following page. If this cable is not connected, the error message **ENCODER ERROR** will be shown on the display and the test stand cannot be operated.

**3. PC Control Connector**

Plug one end of the 09-1056 serial cable into this connector, and the other end into a serial connector on a computer.

**4. Power Plug Receptacle**

Plug the power cord in here.

**5. Travel Indication Connector**

Plug one end of the USB/RJ11 cable into this connector, and the other end into the mini USB connector in the rear of the cross-head.

**6. Force Gauge Cable Connector**

Plug one end of the 09-1143 cable into this connector, and the other end into a Series BG force gauge.



The illustration above depicts proper connection of the controller cable

### 3.5 Connecting Power

Plug one end of the power cord into its receptacle at the rear of the controller and the other end into a wall outlet with local earth ground (3-prong connector).

Before turning on power, the following safety checks and procedures should be performed:

1. Never operate the test stand if there is any visible damage to the power cord or the test stand itself. The ESM301 is powered by 110V/220V. Any contact with this high voltage can cause serious injury or even death.
2. Ensure that the test stand is kept away from water or any other electrically conductive liquids at all times.
3. Make sure the electrical outlet powering the test stand has local earth ground (3-prong connector).
4. The test stand should be serviced by a trained technician only. Power must be disconnected before the controller is opened.

After the above safety checks and procedures have been performed, the test stand may be powered on and is ready for operation.

## 4 OPERATION BASICS

### 4.1 Operational Safety

The following safety checks and procedures should be performed before and during operation:

1. Always consider the characteristics of the sample being tested before initiating a test. A risk assessment should be carried out beforehand to ensure that all safety measures have been addressed and implemented.
2. Wear eye and face protection when testing, especially when testing brittle samples that have the potential to shatter under force. Although the ESM301 has relatively slow moving mechanisms, be aware of the dangers posed by potential energy that can accumulate in the sample during testing. Extra bodily protection should be worn if a destructive failure of a test sample is possible.
3. Keep away from moving parts of the test stand. Loose articles of clothing should not be worn, and long hair should be covered to avoid being caught in any moving parts. A Crush Hazard warning label is located on the base of the test stand. It appears as follows:



**Definition:** Keep any body parts and clothing clear of the area between the base of the test stand and the moving crosshead.

4. In certain applications, such as the testing of brittle samples that can shatter, or other applications that could lead to a hazardous situation, it is strongly recommended that a machine guarding system be employed to protect the operator

and others in the vicinity from shards or debris.

- When the test stand is not in use, ensure that the power is turned off to prevent accidental engagement of any of the controls.

#### 4.2 Controls Layout

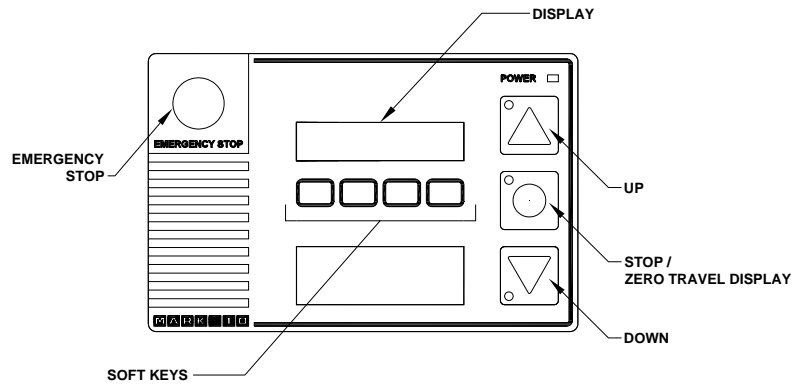

<b>SOFT KEYS</b>	Functions are determined by the corresponding text on the display.
<b>UP</b>	Commences movement in the up direction.
<b>DOWN</b>	Commences movement in the down direction.
<b>STOP / ZERO TRAVEL DISPLAY</b>	Stops crosshead movement / zeroes travel display (if travel indication is enabled).
<b>EMERGENCY STOP</b>	Stops crosshead movement and disables the test stand until reset.

## 5 TEST PARAMETER SETUP

This section provides configuration instructions for each test parameter. Parameters include:

Parameter	Standard / Optional
Units of speed selection	Standard
Speed (same for both directions)	Standard
Password configuration	Standard
Programmable travel limits	Optional
Overload protection	Optional
PC control	Optional
Auto return	Optional
Cycling with dwell time	Optional
Independent up and down speeds	Optional
Programmable button configuration	Optional

All ESM301 test stands are shipped in *Demo Mode*, which provides full functionality of all features (except integrated travel indication) for an evaluation period of 160 operating hours. *Demo Mode* can be disabled by pressing and holding **STOP** while turning on power to the test stand. This mode can be re-enabled in the same fashion, and will be active for the remaining number of hours.

After *Demo Mode* expires, only installed features will be displayed in Test Parameter Setup. The initial Test Parameter Setup screen appears as follows:

```

UNITS:          in/min
ESC  <-  ->  ENTR
    
```



<b>ESC</b>	Exits Test Parameter Setup, reverts to Operating Mode
<b>&lt; -</b>	Scrolls to the previous parameter
<b>- &gt;</b>	Scrolls to the next parameter
<b>ENTR</b>	Selects the parameter, allowing it to be modified

When the parameters have been configured as desired and are

ready to be saved, press **ESC** to exit Test Parameter Setup. The screen will show **SAVE CHANGES?** Pressing **YES** will save the changes and the display will revert to current status. Pressing **NO** will not save the changes and return to the Test Parameter Setup menu.

**Note: Changes can be made to an unlimited number of settings before saving.**

The following is a flow chart for the menu structure:

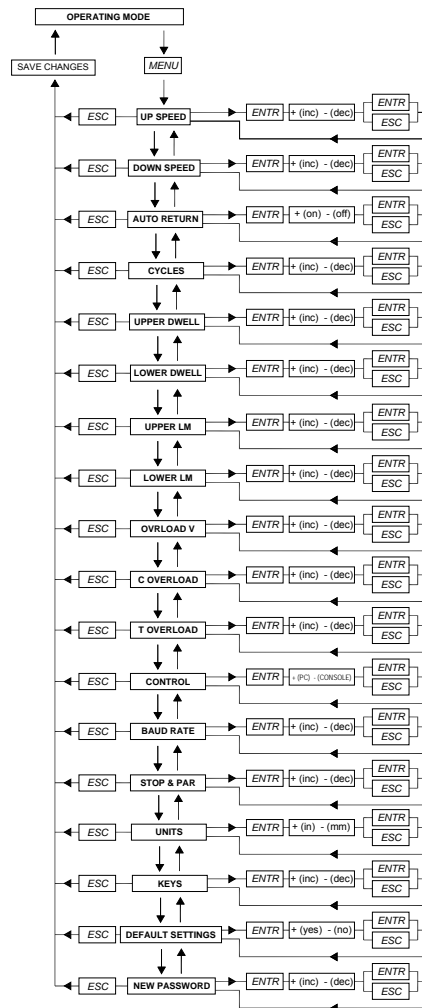

### 5.1 Speed, Up Speed, Down Speed (SPEED, UP SPEED, DN SPEED)

If the independent up and down speed option has not been enabled, the up and down speeds will be the same, and is programmed in the **SPEED** parameter. If independent up and down speeds are enabled, **UP SPEED** and **DN SPEED** parameters will be present, and may be set individually.

*Default setting: 10 in/min*

*Available settings: 0.02 – 45 in/min*

UP SPEED:	10.73
ESC	- + ENTR



<b>+</b>	Increments the speed setting by .01 in or .5 mm. Holding down <b>+</b> will increment at an increasingly faster rate.
<b>-</b>	Decrements the speed setting by .01 in or .5 mm. Holding down <b>-</b> will decrement at an increasingly faster rate.
<b>ENTR</b>	Returns to the Test Parameter Setup menu
<b>ESC</b>	Exits the parameter without saving changes

### 5.2 Auto Return (AUTO RETURN)

With this feature, the crosshead moves to a limit switch, force set point, or travel distance, whichever occurs first, and stops. Then, the crosshead returns to the other limit and stops. The test speed is dictated by the **SPEED** setting or the **UP SPEED** and **DN SPEED** settings. The return speed is always maximum speed.

*Default setting: off*

*Available settings: off, on*

AUTO RETURN:	off
ESC	- + ENTR



<b>+ or -</b>	Cycles through the available settings
<b>ENTR</b>	Returns to the Test Parameter Setup menu
<b>ESC</b>	Exits the parameter without saving changes

**Note:** If **AUTO RETURN** is turned **on**, **CYCLING** is automatically turned **off** and the **KEYS** parameter is automatically set to **MAINTAINED** mode. See following pages for details on the **CYCLING** and **KEYS** parameters.

### 5.3 Cycling (CYCLES)

This setting allows the user to configure the number of up and down cycles through which the crosshead will sequence. One cycle consists of the crosshead moving to a limit switch, force set point, or travel distance, whichever occurs first, at the specified speed, stopping for the specified amount of dwell time, and returning to the other limit at the specified speed. If the independent up and down speed feature is not enabled, the speed will be the same in both directions.

*Default setting: 00000 (off)*  
*Available settings: 00000 – 99999*

CYCLES:	0 0 0 0 0
ESC	- + ENTR



+	Increases the number of cycles in increments of 1. Holding down + will increment at an increasingly faster rate. If 99999 is reached the next number will be 00000 and continue incrementing.
-	Decreases the number of cycles in increments of 1. Holding down - will decrement at an increasingly faster rate. If 00000 is reached the next number will be 99999 and continue decrementing.
<b>Press and hold + and - simultaneously</b>	If pressed and held for 2 seconds or longer the number of cycles will change to 0.
ENTR	Returns to the Test Parameter Setup menu
ESC	Exits the parameter without saving changes

#### 5.4 Upper Limit Dwell Time and Lower Limit Dwell Time (DWELL U and DWELL L)

This setting corresponds to the amount of time, in seconds, for which the crosshead stops at the limit during a cycle sequence.

**Note: the dwell time setting is unavailable for an auto return sequence.**

*Default setting: 0 (no dwell time)*

*Available settings: 0 – 9999.9*

DWELL U:	0 0 0 0 . 0
ESC	- + ENTR



+	Increases dwell time in increments of .1. Holding down + will increment at an increasingly faster rate. If 9999.9 is reached the next number will be 0 and continue incrementing.
-	Decreases dwell time in increments of .1. Holding down - will decrement at an increasingly faster rate. If 0 is reached the next number will be 9999.9 and continue decrementing.
<b>ENTR</b>	Returns to the Test Parameter Setup menu
<b>ESC</b>	Exits the parameter without saving changes

### 5.5 Upper and Lower Travel Limits (UPPER LM and LOWER LM)

This setting corresponds to the travel distance the crosshead moves before stopping or cycling. Upper and lower limits are programmed individually. The programmed distances are relative to the zero position of the crosshead. The travel indicator can be zeroed by pressing and holding **STOP** for 3 seconds.

*Default setting: ±12.000 in*

*Available settings: ±∞*

UPPER LM:	2 . 0 5 8
ESC	- + ENTR



+	Increases the travel limit setting by .001 in or .02 mm. Holding down + will increment at an increasingly faster rate.
-	Decreases the travel limit setting by .001 in or .02 mm. Holding down - will increment at an increasingly faster rate.
<b>ENTR</b>	Returns to the Test Parameter Setup menu
<b>ESC</b>	Exits the parameter without saving changes

### 5.6 Overload Analog Output Voltage (OVRLOAD V)

This setting corresponds to the full scale analog voltage output of the force gauge. The ESM301 protects a force gauge from overload by measuring incoming analog voltage and stopping crosshead travel when the programmed percentage of full scale has been reached (see Section 5.7). The value for Mark-10 gauges is  $\pm 1V$ . Adjustable voltage allows for compatibility with other force gauges as well.

*Default setting: OFF*

*Available settings:  $\pm 1V$ ,  $\pm 2V$ ,  $\pm 4V$ , OFF*

OVRLOAD V:				+ / - 1
ESC	-	+	ENTR	



<b>+ or -</b>	Cycles through the available settings
<b>ENTR</b>	Returns to the Test Parameter Setup menu
<b>ESC</b>	Exits the parameter without saving changes

### 5.7 Compression and Tension Overload Settings (C OVERLOAD and T OVERLOAD)

The setting corresponds to the percentage of full scale of the force gauge at which crosshead travel stops. For example, a setting of 80% for a 50 lb capacity force gauge would stop crosshead travel when 40 lb is reached.

**Note:** When the crosshead is moving in the UP direction, only the tension overload setting applies. When the crosshead is moving in the DOWN direction, only the compression overload setting applies.

*Default setting: 100%*

*Available settings: 20% - 100% (10% increments)*

C OVERLOAD:	20 %
ESC	- + ENTR



<b>+ or -</b>	Cycles through the available settings
<b>ENTR</b>	Returns to the Test Parameter Setup menu
<b>ESC</b>	Exits the parameter without saving changes

### 5.8 Control Source (CONTROL)

This setting corresponds to the source of test stand control. The default value **CONSOLE** sets the test stand to accept commands only from the console (front panel). Any external commands received through the serial port are ignored.

**PC** refers to external control via serial communication. If any parameters are changed on the front panel, these settings will be ignored, except for **Auto Return** or **Cycling**. If either of these parameters are turned on, PC control will be turned off.

*Default setting: CONSOLE*

*Available settings: CONSOLE, PC*

CONTROL:	CONSOLE
ESC	- + ENTR



<b>+ or -</b>	Cycles through the available settings
<b>ENTR</b>	Returns to the Test Parameter Setup menu
<b>ESC</b>	Exits the parameter without saving changes

### 5.9 Baud Rate (BAUD RATE)

This setting corresponds to the baud rate setting of the computer program controlling the test stand.

*Default setting: 9600*

*Available settings:*

*1200, 2400, 4800, 9600, 19200, 38400, 57600, 115200*

BAUD RATE:	9	6	0	0
ESC	-	+	ENTR	



<b>+ or -</b>	Cycles through the available settings
<b>ENTR</b>	Returns to the Test Parameter Setup menu
<b>ESC</b>	Exits the parameter without saving changes

### 5.10 Stop Bits and Parity (STOP & PAR)

This setting corresponds to the stop bits and parity settings of the computer program controlling the test stand.

*Default setting: 8-1n*

*Available settings:*

*8-1E 8 stop bits, 1 stop bit, even parity*  
*8-1o 8 stop bits, 1 stop bit, odd parity*  
*8-1n 8 data bits, 1 stop bit, no parity*  
*8-2n 8 data bits, 2 stop bits, no parity*  
*7-1E 7 data bits, 1 stop bit, even parity*  
*7-1o 7 data bits, 1 stop bit, odd parity*  
*7-2E 7 data bits, 2 stop bits, even parity*  
*7-2o 7 data bits, 2 stop bits, odd parity*  
*7-2n 7 data bits, 2 stop bits, no parity*

STOP & PAR:	8 - 1 n
ESC	- + ENTR



<b>+ or -</b>	Cycles through the available settings
<b>ENTR</b>	Returns to the Test Parameter Setup menu
<b>ESC</b>	Exits the parameter without saving changes

### 5.11 Units of Speed (UNITS)

*Default setting: in/min*

*Available settings: in/min, mm/min*

UNITS:	mm/min
ESC	- + ENTR



<b>+ or -</b>	Cycles through the available settings
<b>ENTR</b>	Returns to the Test Parameter Setup menu
<b>ESC</b>	Exits the parameter without saving changes

### 5.12 Programmable Button Function (KEYS)

Three button function modes are available:

1. **Maintained**  
The crosshead will move continuously once the button has been pressed. Subsequently pressing the **UP**, **DOWN**, or **STOP** during a test will stop crosshead motion.
2. **Momentary**  
The crosshead will move only if the button is held

down. Releasing the button will stop movement immediately.

**3. Auto**

Holding down the button for more than 0.5 seconds will enter momentary mode, at which time an audible indicator will sound and the LED indicator on the button pushed will be illuminated. A short tap on the button will operate the test stand in maintained mode. Pressing **UP**, **DOWN**, or **STOP** during maintained mode will stop crosshead motion.

*Default setting: maintained*

*Available settings: maintained, momentary, auto*

KEYS:	m a i n t a i n e d		
ESC	-	+	ENTR



<b>+ or -</b>	Cycles through the available settings
<b>ENTR</b>	Returns to the Test Parameter Setup menu
<b>ESC</b>	Exits the parameter without saving changes

**5.13 Default Settings (DEFAULT?)**

This setting provides a quick return to factory settings, as follows:

SPEED: **10 in/min**  
 UP SPEED: **10 in/min**  
 DN SPEED: **10 in/min**  
 AUTO RETURN: **off**  
 CYCLING: **00000 (off)**  
 UPPER LM: **+12.000**  
 LOWER LM: **-12.000**  
 OVERLOAD V: **OFF**  
 C OVERLOAD: **100%**  
 T OVERLOAD: **100%**  
 CONTROL: **CONSOLE**  
 BAUD RATE: **9600**

STOP & PAR: **8-1n**  
UNITS: **in/min**  
PASSWORD: **0000 (off)**  
KEYS: **maintained**

*Default setting: off*  
*Available settings: off, on*

DEFAULT?:				NO
ESC	-	+	ENTR	



<b>+ or -</b>	Cycles through the available settings
<b>ENTR</b>	Returns to the Test Parameter Setup menu
<b>ESC</b>	Exits the parameter without saving changes

**5.14 Password (NEW PWORD)**

If desired, a password can be set to prevent unwanted changes to test parameters. The password can be set to any number between 0000 and 9999. The default setting of 0000 indicates that the password is disabled, and that the user can freely enter the Test Parameter Setup menu. If misplaced or forgotten, the password may be reset through a code activation process. Details on this can be found in Section 7.

*Default setting: 0000 (off)*  
*Available settings: 0000 – 9999*

NEW PWORD:				0000
ESC	-	+	ENTR	



+	Increases the number in increments of 1. Holding down + will increment at an increasingly faster rate. If 9999 is reached the next number will be 0000 and continue incrementing.
-	Decreases the number in increments of 1. Holding down - will decrement at an increasingly faster rate. If 0000 is reached the next number will be 9999 and continue decrementing.
<b>ENTR</b>	Returns to the Test Parameter Setup menu
<b>ESC</b>	Exits the parameter without saving changes

## 6 OPERATING MODES

### 6.1 Mode Overview

The ESM301 can be operated in three modes:

1. **Basic Mode**  
Manual control of crosshead motion.
2. **Auto Return Mode**  
Crosshead moves to a limit switch, force set point, or travel distance, whichever occurs first, then reverses and moves at maximum speed to the other limit, whichever occurs first.
3. **Cycling Mode**  
Crosshead cycles between limits at the selected speed, and pauses at each limit or set point for a selected period of time.
4. **PC Mode**  
Test stand is controlled through a serial connection with a computer.

The Operating Mode screen appears as follows:

Speed:	0.00
menu min max SET	



If travel indication is enabled, the screen appears as follows:



<b>menu</b>	Enters Test Parameter Setup
<b>min</b>	Sets speed to minimum speed
<b>max</b>	Sets speed to maximum speed
<b>set</b>	Sets speed to the programmed SPEED, UP SPEED, or DN SPEED setting

The item selected will be capitalized, as shown in the figure above. The **set** speed can be changed in Test Parameter Setup. If enabled, the up and down speeds can be configured independently of each other (**UP SPEED** and **DN SPEED**). Otherwise, the **SPEED** setting corresponds to crosshead speed in both directions.

### 6.2 Menu Navigation

At power-up, the display will show the operation screen for whichever mode was used last. The display will appear as one of the following:

#### Basic & Auto Return Modes (travel indication not enabled):



**Basic & Auto Return Modes (travel indication enabled):**

TRAVEL	SPEED
↓	↓
1.275	0.00
menu min max SET	



**Cycling Mode (travel indication not enabled):**

CYCLES:	00024
menu min max SET	



**Cycling Mode (travel indication enabled):**

TRAVEL	CYCLES REMAINING
↓	↓
1.275	00024
menu min max SET	



**PC Mode:**

Appears the same as in Basic and Auto Return modes.

Pressing **menu** will enter Test Parameter Setup. If a password has been programmed, the display will prompt the following:

PASSWORD:	0000
ESC + -> ENTR	



The password is a four digit number. The first digit in the password

will be flashing, signifying that it is active and can be incremented by pressing **+**. To advance to the next digit, press **→**. Change subsequent digits in the same fashion. Once the complete password has been entered, press **ENTR**. If correct, the display will enter Test Parameter Setup Mode. If the password is incorrect, the words **INCORRECT PASSWORD** will flash, and the display will revert to Operating Mode.

### 6.3 Basic Mode

The crosshead moves upward when **UP** is pressed, and downward when **DOWN** is pressed. When the crosshead is in motion, an LED indicator on the button pushed will be illuminated. The **KEYS** setting controls how crosshead movement responds to the push of the **UP** and **DOWN** buttons. The three settings are:

1. **Maintained (default)**

The crosshead will move continuously once the button has been pressed. Subsequently pressing **STOP** during a test will stop crosshead motion.

2. **Momentary**

The crosshead will move only if the button pressed and held. Releasing the button will stop movement immediately.

3. **Auto**

Holding down the button for more than 0.5 seconds will enter **Momentary** mode, at which time an audible indicator will sound and the LED indicator on the button pushed will be illuminated. A short tap on the button will operate the test stand in **Maintained** mode. Pressing **STOP** during **Maintained** mode will stop crosshead motion. To resume the test, press **UP** or **DOWN** again.

Pressing **EMERGENCY STOP** will immediately stop crosshead motion in any mode. To release, twist the button counter-clockwise until it assumes its original position. To resume the test, press **UP** or **DOWN**.

Crosshead movement will take place until a limit switch, force set point, or travel distance set point has been reached. If the crosshead has stopped at a force set point or travel distance set point,

the limit condition may be overridden by pressing and holding **UP** or **DOWN** for two seconds.

### 6.3.1 Travel Indication

If enabled, travel indication is displayed in the upper left corner of the display. The displayed units are the same as programmed in the **UNITS** parameter. Indicated travel is a relative value. To zero out travel distance, ensure that the crosshead is not moving, then press and hold **STOP** for three seconds.

If the cable connecting the crosshead to the rear of the controller is unplugged, the error message **ENCODER ERROR** will appear. To clear the message, insert the cable, then press **STOP**.

### 6.3.2 Limit Switch Operation

Limit switches allow the operator to set a location along the column at which point the crosshead will stop moving. Limit switches are located at the rear of the test stand column. Adjust the switches' positions by loosening, repositioning, and re-tightening the thumb screws.

### 6.3.3 Overload Protection

The 09-1143 cable is required for overload protection of a Mark-10 force gauge. If overload protection is enabled, the crosshead will stop when the programmed percentage of full scale of the force gauge has been reached.

When overload protection is enabled, if the 09-1143 cable is disconnected, and/or if the force gauge is turned off, the error message **GAUGE ERROR** will appear. Plug in the cable and/or turn on the force gauge to clear the message.

**Note:** When the crosshead is moving in the UP direction, only the tension overload setting is active. When the crosshead is moving in the DOWN direction, only the compression overload setting is active.

#### 6.4 Auto Return Mode

With this setting, the crosshead moves to a limit switch, force set point, or travel distance, whichever occurs first, and stops. Then, the crosshead returns at maximum speed to the other limit, whichever occurs first, and stops. The speed at which the crosshead travels is dictated by the **SPEED** setting or **UP SPEED** and **DN SPEED** settings (if independent speeds is enabled). Press **UP** or **DOWN** to initiate an Auto Return sequence.

The crosshead can be stopped at any time during an Auto Return sequence by pressing **STOP**. To resume the test, press **UP** or **DOWN**.

If the crosshead has stopped at a force set point or travel distance set point, the limit condition may be overridden by pressing and holding **UP** or **DOWN** for two seconds.

Travel indication and limit switch operation is the same as in Basic Mode.

#### 6.4 Cycling Mode

This mode cycles the crosshead between limit switches, force set points, or travel distance set points, whichever occurs first. One cycle consists of the following steps:

1. Crosshead moves to a limit at the specified speed.
2. Crosshead stops for the specified amount of dwell time.
3. Crosshead reverses direction, returns to the other limit at the specified speed, and stops.

A cycling sequence can be initiated from any position and can start in either direction. If the crosshead is at a limit, however, cycling can only be started in the direction of the other limit. To initiate a cycle sequence, press **UP** or **DOWN**. During a cycle sequence, a counter will be displayed, indicating the number of cycles remaining, as shown below:

CYCLES:	0	0	2	4
menu	min	max	SET	



As in Basic Mode, the **min**, **max**, and **set** soft keys are active during crosshead movement.

When the cycling sequence and the crosshead has stopped at a force set point or travel distance set point, the limit condition may be overridden by pressing and holding **UP** or **DOWN** for two seconds.

#### 6.4.1 Dwell time

Dwell time is the amount of time, in seconds, for which the crosshead stops at a limit during a cycle sequence. When the crosshead has reached a limit, a counter will be displayed, shown as follows:

DWELL:	0	0	1	.5
menu	min	max	SET	



If the **DWELL U** and/or **DWELL L** settings are set to 0, the crosshead will immediately reverse direction upon reaching the corresponding limit, and no counter will be displayed.

The cycle sequence may be interrupted before it has been completed by pressing **STOP**. A soft key labeled **RESET** will appear as follows:

CYCLES:	0 0 0 2 4
	RESET



At this point, there are two options:

- 1. Canceling the cycle sequence:**  
Press **RESET** to stop and reset the cycle sequence.  
The cycle counter will revert to the number of cycles originally programmed.
- 2. Resuming the cycle sequence:**  
Press **UP** or **DOWN** to resume.

Once the sequence has been completed, the screen will revert to the number of cycles programmed originally. To begin another cycle test, press **UP** or **DOWN**.

Travel indication and limit switch operation is the same as in Basic Mode.

## 6.5 PC Mode

The ESM301 can be controlled by a computer via serial communication. A list of supported ASCII commands is provided below. All commands must be lowercase.

a	Request speed
b	Set travel units to inches
c	Enter cycle mode
d	Move crosshead down
e	Set speed (ex. e10.00 = 10.00 in/min)
f	Set cycles (ex. f0500 = 500 cycles)
g	Set lower travel limit (ex. g05.375 = 5.375 in)
h	Set upper travel limit (ex. h10.250 = 10.250 in)
i	Set travel units to millimeters
j	Set crosshead speed to maximum speed
k	Set crosshead speed to minimum speed
l	Enter travel limit mode
m	Enter manual mode
n	Transmit travel and force readings
o	Set crosshead speed to programmed speed
p	Request stand status*
q	Request number of cycles completed
r	Request number of cycles set
s	Stop crosshead
t	Reset cycle counter to zero
u	Move crosshead up
v	Request upper travel limit
w	Request lower travel limit
x	Request travel value
z	Reset travel to zero

\*The transmission of ASCII "p" will return the stand status. The following are the return codes and their definitions:

Crosshead status	U = crosshead moving up D = crosshead moving down S = crosshead stopped
Operating mode	C = cycle mode L = limit mode M = manual mode

---

Limit switch status      UL = crosshead at upper limit  
   DL = crosshead at lower limit

Commands relating to Mark-10 force gauges are NOT the same as indicated in the respective user's guides. A list of supported ASCII commands is provided below. All commands must be uppercase:

A	Displays current unit
F	Toggles between Normal and Data Collect modes
P	Steps through Normal mode, Tension Peak mode, and Compression Peak mode
R	Zeroes the force gauge (zeroes all modes)
S	Sends currently selected mode (Normal, Tension Peak, Compression Peak, or Data Collect)
U	Steps through units
X or ?	Sends currently displayed reading
Y	Enables RS-232 output and sends continuous data stream when in Data Collect mode
Z	Zeroes the currently selected mode

The ESM301 is compatible with Nexygen™ TCD software, which also utilizes the above commands. The 09-1143 cable is needed to communicate between a Mark-10 gauge and the test stand.

The 09-1056 serial cable is needed to communicate between a computer and the test stand. Baud rate, stop bits and parity must be programmed in the stand to correspond with the computer program's settings. Details on this are provided in Section 5.

While in PC control, if any parameters are changed on the front panel, these settings will be ignored, except if Auto Return or Cycling are turned on. If so, PC control will be turned off automatically.

## **8 COMMUNICATING WITH MESURGAUGE**

The ESM301 can communicate with MESURgauge data collection software. The test stand can output either force data only or force data combined with travel data (if the ESM301-001 integrated travel indication option is installed). To communicate with MESURgauge, certain settings in the test stand, force gauge, and software must be changed as follows:

### 8.1 Force data only

1. Check physical connections (refer to Section 3.4).
2. Force gauge settings (refer to the gauge's user's guide).
  1. Set to automatic output of every sample.
  2. Disable Mitutoyo BCD output.
3. Test stand settings
  1. Set the baud rate to 115,200.
  2. Set the Control mode to Console.

### 8.2 Force and travel data simultaneously

1. Check physical connections (refer to Section 3.4)
2. MESURgauge settings
  1. Test Setup tab
    1. Under *Travel* check the *Enable* box. Under *Reading Mode*, if *Continuous Readings* is selected, *Readings per Sec.* defaults to 4. This value can be increased.
  3. Port Configuration tab
    1. Identify a working com port, and select the appropriate port in *Gauge Port Settings*.
    2. Under *Gauge Port Settings*, change baud rate to 115,200.
    2. Under *Reading Request String* change *String to Write* to "n" (lowercase, no quotes). Uncheck the CR box.
    3. Check the box labeled *Travel Data Combined with Load Data*. No changes are needed to the

default lines, fields, and delimiter.

4. Click APPLY after making any changes in the *Gauge Port Settings* area.
3. Force gauge settings (refer to the gauge's user's guide)
  1. Set to automatic output of every sample.
  2. Disable Mitutoyo BCD output.
4. Test stand settings
  1. Set the baud rate to 115,200.
  2. Set the Control mode to Console.
5. The Gauge Settings tab and all other gauge-related functions cannot be used while MESURgauge is connected to the ESM301. It is intended for use only when connected to a Mark-10 force gauge directly.

## 9 FEATURE ACTIVATION

This menu displays the features that are enabled and disabled. Those that are disabled can be activated. Features that are enabled are indicated by **ON**, and those that are disabled are indicated by **OFF**.

### 9.1 Accessing Feature Activation Menu

While in Operating Mode, press **STOP** and **menu** simultaneously.

The display will appear as follows:

KEYS:				O F F
ESC	<-		->	ENTR



<-	Scrolls to the previous feature
->	Scrolls to the next feature
<b>ENTR</b>	Selects the feature
<b>ESC</b>	Exits Feature Activation Menu

The Feature Activation Menu also includes a utility with which to reset the password. To reset the password, scroll through the features until the following is displayed:

CLEAR PASSWORD?
ESC <- -> ENTR



Press **ENTR** to clear the password, or **ESC** to re-enter the menu.

## 9.2 Enabling Features

Features not originally purchased can be activated with an *authorization code*. To activate the feature, scroll through the menu until the desired feature is displayed, then press **ENTR**. If the feature is already enabled (indicated by **on**), pressing **ENTR** has no effect. If the feature is off, pressing **ENTR** will bring up a *request code* on the display.

An example is shown below:

KEYS:	0	1	3	9	0	2	7
ESC	+	->	ENTR				



The *request code* must be supplied to Mark-10 or a distributor, who will then provide a corresponding *authorization code* to activate the feature.

The process for entering the *authorization code* is as follows:

1. The first digit of the *request code* will be flashing. Press **+** to increment the digit. Pressing **+** when the number 9 is displayed will return to 0.
2. Press **->** to advance to subsequent digits, and change them in the same fashion.
3. Press **ENTR** to enable the feature. If an incorrect code is entered, the controller will return to the Feature Activation Setup menu, without enabling the feature. If this happens the above process must be repeated.

### 9.3 Demo Mode

All ESM301 test stands are shipped in *Demo Mode*, which provides full functionality of all available features (except integrated travel indication) for an evaluation period of 160 operating hours. *Demo Mode* can be disabled by pressing **STOP** while turning on power to the test stand. This mode can be re-enabled in the same fashion, and will be active for the remaining time period.

## 10 MAINTENANCE AND SERVICE

The ESM301 should be operated in a dry and clean area. Under these circumstances only a few periodic maintenance operations are required:

### 10.1 Acme screw lubrication – twice per year

1. Remove the right column cover by loosening the screws, as shown in the following illustration:



2. Using a brush, apply a small amount of silicon-based grease to the lead screw.
3. Cycle the crosshead up and down several times until the newly applied grease has been spread evenly over

the length of the screw. Re-install the column cover.

### **10.2 Check for loosened grips and attachments - daily**

Check to ensure that the grips attached to the force gauge and base plate are firmly secured. Looseness could result in a potentially hazardous situation.

### **10.3 Check for loosened components – once per month**

1. Remove the test sample from the test stand.
2. Turn off power to the test stand and disconnect the power cord. Attempt to loosen subcomponents of the test stand (ex. fasteners, brackets, etc). All components should be firmly attached. If any looseness is detected, stop using the test stand and contact Mark-10 or a distributor for instructions.

## 11 SPECIFICATIONS

Load capacity	300 lbf [1.5 kN] @ Up to 24 in/min [610 mm/min] 200 lbf [1 kN] @ >24 in/min [>610 mm/min]
Standard speed range	0.5-13 in/min [13-330 mm/min]
Maximum travel	11.5 in [292 mm]
Speed setting accuracy	±0.2%
Speed variation with load	±0% [Stepper motor driven]
Limit switch repeatability	0.001 in [0.03 mm]
Travel accuracy:	±0.002 in [0.05 mm]
Travel repeatability:	0.001 in [0.03 mm]
Travel resolution	0.001 in / 0.02 mm
Power	Universal input 80-240 VAC, 50/60 Hz
Fuse type	1.2 A, 250V, 3AG, SLO BLO
Weight (without options)	34 lbs [15.4 kg]
Included accessories:	Extension rod, small hook, medium hook, #10-32 coupler, compression plate, force gauge mounting hardware, tool kit

## 12 DIMENSIONS

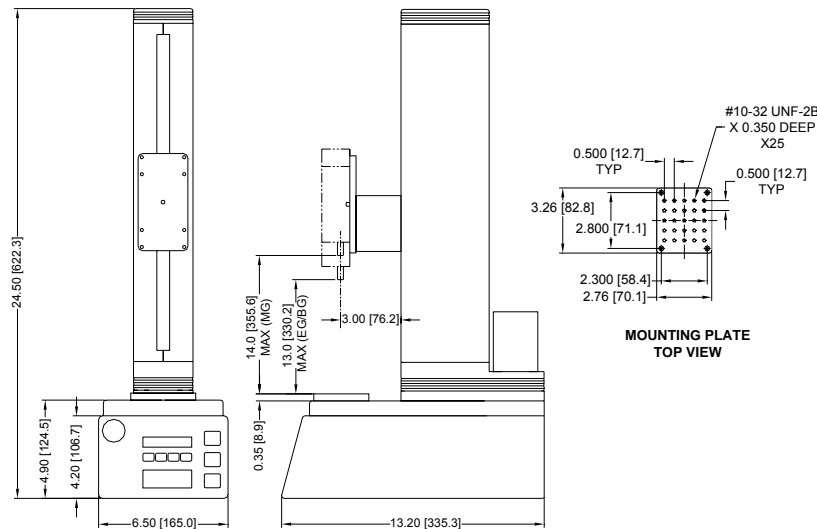

**NOTES:**